

# MI0603J601R-10

**UNCONTROLLED DOCUMENT**

PHYSICAL DIMENSIONS:

A	1.60 [.063]	+ 0.15	-.006	[.006]
B	0.80 [.031]	+ 0.15	-.006	[.006]
C	0.80 [.031]	+ 0.15	-.006	[.006]
D	0.36 [.014]	+ 0.15	-.006	[.006]

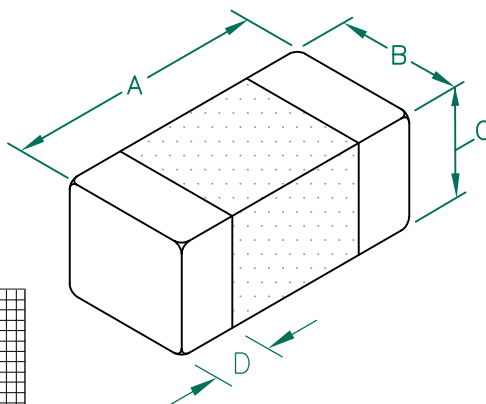

ELECTRICAL CHARACTERISTICS:

Z @ 100MHz (Ω)	DCR (Ω)	Rated Current
Nominal	600	
Minimum	450	
Maximum	750	0.20
		1000 mA

NOTES: UNLESS OTHERWISE SPECIFIED

1. TAPED AND REELED per CURRENT EIA SPECIFICATIONS 7" REELS, 4000 PCS/REEL.
2. TERMINATION FINISH IS 100% TIN.
3. COMPONENTS SHOULD BE ADEQUATELY PREHEATED BEFORE SOLDERING.
4. OPERATING TEMP. RANGE: -40°C~+125°C. (INCLUDING SELF-HEATING)

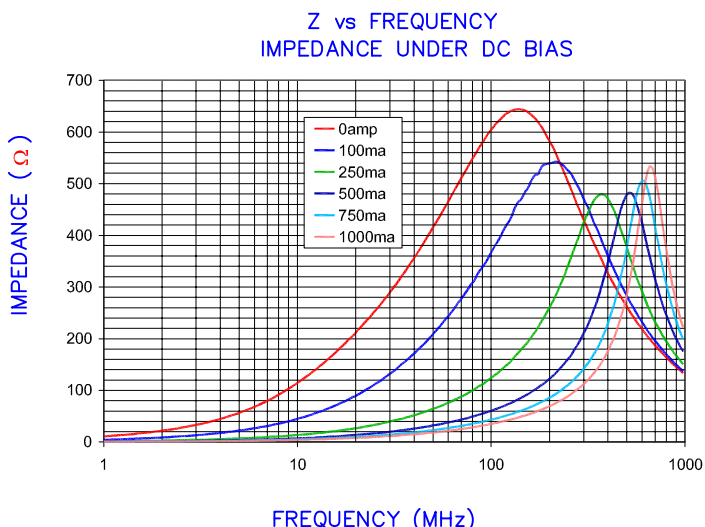

LAND PATTERNS FOR REFLOW SOLDERING

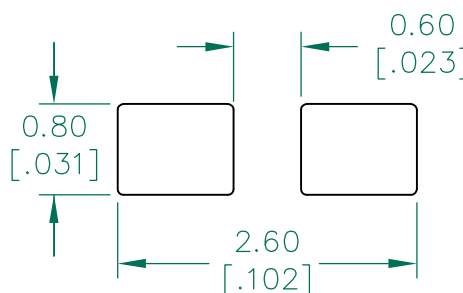

(For wave soldering, add 0.762 [.030] to this dimension)

RECOMMENDED SOLDERING CONDITIONS

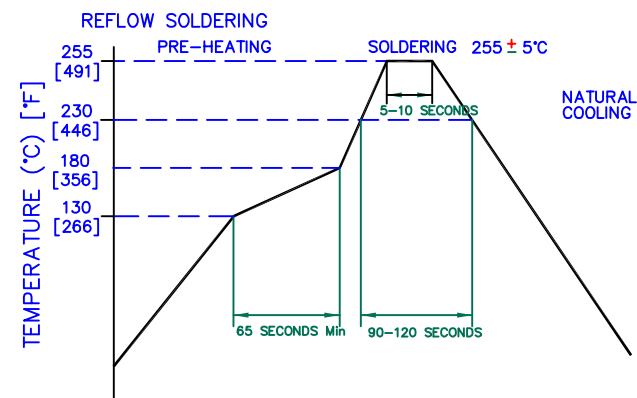

FREQUENCY (MHz)  
|Z|, R, AND X vs. FREQUENCY

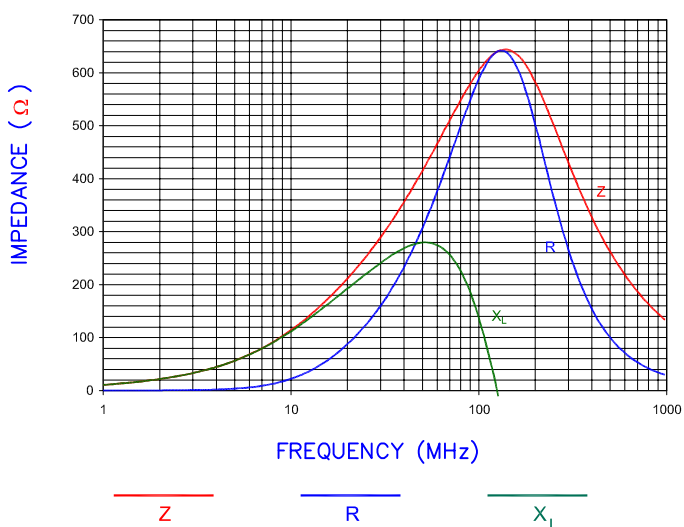

DIMENSIONS ARE IN mm [INCHES].				This print is the property of Laird Tech. and is loaned in confidence subject to return upon request and with the understanding that no copies shall be made without the written consent of Laird Tech. All rights to design or invention are reserved.			
				<b>Laird</b>			
PROJECT/PART NUMBER:				REV	PART TYPE:	DRAWN BY:	
C	ADD OPERATING TEMPERATURE UPDATE LAIRD LOGO AND REFLOW CURVE	08/05/13	QU	MI0603J601R-10	C	CO-FIRE	TMB
B	UPDATE COMPANY LOGO	07/24/08	JRK	DATE: 04/05/04	SCALE: -	SHEET: 1 of 1	
A	ORIGINAL DRAFT	04/05/04	TMB	CAD # MI0603J601R-10-C	TOOL # -		
REV	DESCRIPTION	DATE	INT				